



Finiture

Finishes / Ausführungen / Finitions / Отделки

M (Cat 1) = Laccato opaco / Matt lacquered / Matt lackiert / Laqué mat / Лак матовый
G (Cat 2) = Laccato lucido / Gloss lacquered / Glanz lackiert / Laqué brillant / Лак глянцевый
D (Cat 4) = Laccato metallizzato lucido / Glossy metallic lacquered / Lackiert in Metallikfarbe glanz / Laqué métallisé brillant / Лак металлизированный глянцевый

Per laccati a campione, maggiorazione del 20% sul prezzo di listino.
 For customer's sample lacquers, add a 20% surcharge on top of the pricelist price / Sonderlackfarben auf Anfrage möglich: Mehrpreis 20% auf Bruttolistenpreis / Pour les laques sur échantillon, supplément de 20% sur le prix du tarif / В случае лакировки по образцу заказчика наценка составит 20% на цену прайс-листа.

LACCATI / Lacquer finishes / Lackfarben / Finitions Lacqués / Лакировка глянцевая или матовая

					
G/M 0050 Bianco ghiaccio	G/M 0051 Bianco latte	G/M 0058 Papiro	G/M 0052 Corda elegance	G/M 0053 Sabbia	G/M 0054 Tortora elegance
					
G/M 0074 Ciclamino	G/M 0075 Orchidea	G/M 0055 Avana	G/M 0083 Beige Arizona	G/M 0065 Nuvola	G/M 0059 Grigio elegance
					
G/M 0078 Grey	G/M 0079 Trim Grey	G/M 0080 Green	G/M 0076 Castoro	G/M 0063 Verde salice	G/M 0056 Caffè elegance
					
G/M 0068 Blu notte	G/M 0066 Bluette	G/M 0077 London Grey	G/M 0057 Fango	G/M 0064 Verde muschio	G/M 0060 Grigio pietra
					
G/M 0082 Grigio Bromo	G/M 0067 Blu elegance	G/M 0069 Blu oltremare	G/M 0061 Antracite dark	G/M 0062 Nero Lavagna	G/M 0081 Rosso Jaipur
					
G/M 0072 Ruggine	G/M 0073 Rosso Vivo	G/M 0071 Arancio Acero	G/M 0070 Giallo Senape		

Laccati metallizzati lucidi / Glossy metallic lacquered / Lackiert in glänzenden metallisierten Farben / Laqué métallisé brillant / Лакочерасочная глянцевая металлизированная покраска

					
D0001 Prosecco	D0005 Light Grey	D0003 Bronze	D0002 Gold	D0004 Gianduia	D0006 Dark Grey

Finiture

Finishes / Ausführungen / Finitions / Отделки

- VL (Cat 3)** = Vetro colorato lucido / Gloss lacquered glass / Glas glanz / Verre coloré brillant / Стекло цветное гляцевое
- VS (Cat 4)** = Vetro colorato satinato / Satin lacquered glass / Glas satiniert / Verre coloré satiné / Стекло цветное Сатинированное
- VD (Cat 5)** = Vetro lucido metallizzato / Metallic lacquered glass / Glas "Metallic" / Verre coloré métallisé / Стекло цветное металлизированное
- VR (Cat 6)** = Vetro colorato cannettato / Colored ribbed glass / Geriffeltes, farbiges Glas / Verre cannelé coloré / Стекло рифленое цветное

Per vetri colorati a campione, maggiorazione del 20% di listino rispetto al prezzo del vetro lucido metallizzato.

For lacquered finishes matching customer's sample, a 20% surcharge is applied to the price of gloss metallic lacquered glass / Sonderglasfarben auf Anfrage, Aufpreis von 20% auf Listenpreis des Glases in den Metallikfarben / Pour les verres colorés selon échantillon, augmentation de prix de 20% par rapport au prix du verre métallisé brillant / При заказе цветного стекла по образцу - наценка 20% к стоимости гляцевого металлизированного стекла по прайс-листу.

VETRO / Glass / Glas / Verre / Стекло

					
VL/VS 050 Bianco ghiaccio	VL/VS 051 Bianco latte	VL/VS 058 Papiro	VL/VS052 Corda elegance	VL/VS 053 Sabbia	VL/VS 0054 Tortora elegance
					
VL/VS 0074 Ciclamino	VL/VS 075 Orchidea	VL/VS 0055 Avana	VL/VS 0083 Beige Arizona	VL/VS 0065 Nuvola	VL/VS 0059 Grigio elegance
					
VL/VS 0078 Grey	VL/VS 0079 Trim Grey	VL/VS 0080 Green	VL/VS 0076 Castoro	VL/VS 0063 Verde salice	VL/VS 0056 Caffè elegance
					
VL/VS 068 Blu notte	VL/VS 0066 Bluette	VL/VS 0077 London Grey	VL/VS 0057 Fango	VL/VS 0064 Verde muschio	VL/VS 0060 Grigio pietra
					
VL/VS 0082 Grigio Bromo	VL/VS 0067 Blu elegance	VL/VS 0069 Blu oltremare	VL/VS 0061 Antracite dark	VL/VS 0062 Nero Lavagna	VL/VS 0081 Rosso Jaipur
					
VL/VS 0072 Ruggine	VL/VS 0073 Rosso Vivo	VL/VS 071 Arancio Acero	VL/VS 070 Giallo Senape		
					
VD001 Prosecco	VD002 Gold	VD004 Bronze	VD005 Gianduia	VD006 Light grey	VD003 Dark grey



Vetro colorato cannettato

Nella collezione Eden disponibile nella variante cannettata colorata.

Available in the Eden collection in the colored ribbed variant
Erhältlich in der geriffelten Variante in der Kollektion Eden
Dans la collection Eden disponible dans la variante cannelée colorée.
Рифленая цветная отделка в коллекции Eden

Finiture

Finishes / Ausführungen / Finitions / Отделки

LEGNO / Wooden finish / Holz / Bois / Дерево



E0022 (Cat.3)
White Chestnut



E0019 (Cat.5)
Oak Carved



E0006 (Cat.3)
Sand Oak



E0024 (Cat.3)
Hemp Chestnut



E0023 (Cat.3)
Grey Chestnut



E0020 (Cat.5)
Walnut Carved



E0012 (Cat.4)
Walnut



EP002 (Cat.5)
Makassar



EP003 (Cat.5)
Dark Mahogany



EP001 (Cat.5)
Ammara Ebony



E0025 (Cat.3)
Black Chestnut



E0026 (Cat.4)
Heat Treated Oak



E0027 (Cat.3)
Charcoal Oak



E0028 (Cat.4)
Eucalyptus

Finiture

Finishes / Ausführungen / Finitions / Отделки

PELLE / Leather / Leder / Cuir / Кожа

Solo per frontali cassetto / Only for frontal drawers / Nur für die Schubladenfronten /
Pour les façades des tiroirs uniquement / Только для отделки ящиков снаружи

(Cat. 7)



STAMPA PELLE DELUXE / Leather print deluxe / Leder Variante „Deluxe” / Impression cuir de luxe / Кожа с течением Deluxe

Solo per frontali cassetto / Only for frontal drawers / Nur für die Schubladenfronten /
Pour les façades des tiroirs uniquement / Только для отделки ящиков снаружи

(Cat. 7)



Finiture

Finishes / Ausführungen / Finitions / Отделки

MARMI / Marbles / Marmorplatten / Marbres / Мрамор



L0008 (Cat.8)
Lasa fantastico



L0001 (Cat.5)
Bianco carrara



L0009 (Cat.7)
Bianco statuario



L0010 (Cat.9)
Calacatta oro



L0014 (Cat.1)
Pietra medea



L0002 (Cat.2)
Bardiglio nuvolato

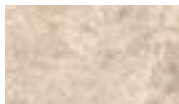

L0004 (Cat.3)
Emperador light



L0013 (Cat.10)
Onice striato



L0011 (Cat.9)
Calacatta viola



L0012 (Cat.4)
Nero zebrato



L0003 (Cat.2)
Nero marquina



L0006 (Cat.6)
Nero assoluto



L0007 (Cat.6)
Mystic brown



L0005 (Cat.3)
Emperador dark

Marmi e Graniti sono materiali naturali e preziosi, soggetti a variazioni di venatura e colore. Di conseguenza ogni singolo marmo costituisce un pezzo unico con sfumature e caratteristiche che variano a seconda del livello di estrazione della lastra. La campionatura fornisce solo un'indicazione della tonalità e della venatura che può essere fornita.

Non sarà accettata alcuna contestazione per eventuali differenze tra i campioni ed i marmi o graniti consegnati.

Marble and Granite are natural, precious materials that by nature are subject to variations in vein and colour.

Consequently, each marble slab is unique and has shades of colour and features that differ from any other depending on where it has been quarried from. Samples are purely indicative of the shade and vein that may be supplied.

Complaints concerning possible differences between the samples and the marble or granite actually supplied will not be accepted.

Marmor und Granit sind edle Naturmaterialien mit unterschiedlicher Maserung und Farbe.

Demnach stellt jede einzelne Marmorplatte ein Einzelstück dar, dessen Schattierungen und Merkmale von der Abbauschicht im Marmorbruch abhängig sind. Die Muster stellen lediglich einen Anhaltspunkt für die Farben und Maserungen dar, die geliefert werden können.

Beanstandungen für eventuelle Unterschiede zwischen den Mustern und den gelieferten Marmor- und Granitplatten werden keinesfalls akzeptiert.

Les Marbres et les Granits sont des matériaux naturels et précieux qui ont des veines et des couleurs différentes.

En conséquence, chaque marbre constitue une pièce unique avec des nuances et des caractéristiques qui varient selon le niveau d'extraction de la plaque. L'échantillonnage ne fournit qu'une indication de la tonalité et des veines du marbre ou du granit choisi.

Toute différence entre les échantillons et les marbres ou granits livrés ne pourra en aucun cas faire l'objet d'une quelconque réclamation.

Мрамор и гранит являются ценными материалами естественного происхождения, чей цвет и расположение прожилок подвержены изменениям. Поэтому каждая мраморная столешница уникальна по своему оттенку и характеристикам, отличающимися в зависимости от залегающей добываемой плиты. Предлагаемые образцы мрамора и гранита служат лишь индикацией на тон и расположение прожилок на изделиях.

Возможные отличия поставляемого мрамора или гранита от существующих образцов не будут рассматриваться в качестве рекламации.

Finiture

Finishes / Ausführungen / Finitions / Отделки

GRES / Porcelain stone / Feinsteinzeug / Gres Cerame / Керамогранит

Top, Frontali e fianchi / Tops, frontals and sides / Abdeckplatte, Fronten und Seitenteile / Plans, façades et côtés / Столешницы, фасвды и боковины

(Cat. 6)



B0009
Statuarietto

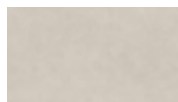

B0010
Sale



B0011
Pietra Piasentina



B0012
Pietra Grey Opaco



B0013
Fokos roccia



B0014
Jatoba brown



B0008
Noir desir



B0015
Alaska white

FENIX / Fenix / Fenix / Fenix / Феникс

Solo per top / For tops only / Nur für die Abdeckplatten / Pour les plans uniquement / Только для столешницы



FX001
White



FX005
Grey



FX007
Green



FX012
Grigio Bromo



FX002
Castoro



FX003
London Grey



FX011
Rosso Jaipur



FX008
Black

Finiture dei Top

Tops' finishes / Ausführung der Abdeckplatten / Finitions des plans / Виды отделки столешницы

PUREFEEL BIANCO/COLORATO OPACO / White/coloured matt Purefeel / Purefeel Weiss/gefärbt in matt / Purefeel blanc/coloré mat / Пурефил матовый белый

Solo per top / For tops only / Nur für die Abdeckplatten / Pour les plans uniquement / Только для столешницы



Bianco ghiaccio



Bianco latte

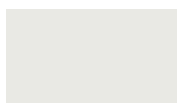

Papiro

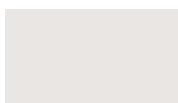

Corda elegace



Sabbia



Tortora elegace



Ciclamino



Orchidea



Avana



Beige Arizona



Nuvola



Grigio elegace



Grey



Trim Grey



Green



Castoro



Verde salice



Caffè elegace



Blu notte



Bluette



London Grey



Fango



Verde muschio



Grigio pietra



Grigio Bromo



Blu elegace



Blu oltremare



Antracite dark



Nero Lavagna



Rosso Jaipur



Ruggine



Rosso Vivo



Arancio Acero



Giallo Senape

CORIAN® / Corian / Corian / Corian / (Кориан) белый матовый

Solo per top / For tops only / Nur für die Abdeckplatten / Pour les plans uniquement / Только для столешницы



Bianco opaco / Matt White / Weiss matt / Blanc mat / Белый матовый

GEACRIL® / Porcelain Stone / Feinsteinzeug / Gres Cerame / Керамогранит

Solo per top / For tops only / Nur für die Abdeckplatten / Pour les plans uniquement / Только для столешницы



Bianco lucido / Glossy White / Weiss glanz / Blanc brillant / Белый гляцевый

Finiture dei Top

Tops' finishes / Ausführung der Abdeckplatten / Finitions des plans / Виды отделки столешницы

LIGHTFEEL BIANCO/COLORATO OPACO / White/coloured matt Lightfeel / Lightfeel Weiss/gefärbt in matt / Lightfeel blanc/coloré mat / Lightfeel матовый белый

Solo per top / For tops only / Nur für die Abdeckplatten / Pour les plans uniquement / Только для столешницы



Bianco ghiaccio



Bianco latte

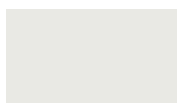

Papiro

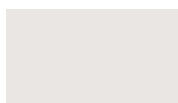

Corda elegace



Sabbia



Tortora elegace



Ciclamino



Orchidea



Avana



Beige Arizona



Nuvola



Grigio elegace



Grey



Trim Grey



Green



Castoro



Verde salice



Caffè elegace



Blu notte



Bluette



London Grey



Fango



Verde muschio



Grigio pietra



Grigio Bromo



Blu elegace



Blu oltremare



Antracite dark



Nero Lavagna



Rosso Jaipur



Ruggine



Rosso Vivo



Arancio Acero



Giallo Senape

Imballi

Packagings / Verpackungen / Emballages / Упаковка



> Il prezzo dell'imballo è netto

The price of the wooden packaging is a net price.
Der Preis der Holzverpackung versteht sich als Nettopreis.
Le prix de l'emballage est net.
Стоимость деревянной упаковки нетто.

A Imballo su pallet standard compreso nel prezzo del prodotto

Packaging on standard pallet included in the price of the furniture
Der Preis des Möbels versteht sich inklusiv die Standardverpackung auf Palette / Emballage sur palette compri dans le prix du meuble
Упаковка на стандартной паллете включена в стоимость изделия



B Imballo con cassa in legno OSB

Packaging in OSB wooden box.
Verpackung in Holzkiste aus Holz OSB
Emballage avec caisse en bois OSB
Упаковка в ящике из ОСП
(ориентированная стружечная плита)

Prezzo netto
Net price
Nettopreis
Prix net
Стоимость нетто

Cassa fino a 120x80xH120 cm

Box with dimensions until 120x80xH120 cm
Holzkiste mit Massen bis 120x80x120 (H) cm
Caisse jusq'à 120x80x120 cm
Ящик размерами до 120x80xh120 cm

405

Cassa fino a 160x80xH120 cm

Box with dimensions until 160x80xH120 cm
Holzkiste mit Massen bis 160x80x120(H) cm
Caisse jusq'à 160x80x120 cm
Ящик размерами до 160x80xh120 cm

486

Cassa fino a 200x80xh120 cm

Box with dimensions until 200x80xH120 cm
Holzkiste mit Massen bis 200x80x120(H) cm
Caisse jusq'à 200x80x120 cm
Ящик размерами до 200x80xH120 cm

584

Casse di dimensioni diverse dovranno essere quotate dall'ufficio commerciale Oasis

For boxes with different dimensions please contact our sales dept. to get a quotation.
Holzkisten in speziellen Massen auf Anfrage bei der Verkaufsabteilung von Oasis.
Pour caisses en bois de differenets dimensions contacter le bureau commercial de Oasis / Стоимость ящиков других размеров подлежит индивидуальному расчету коммерческого отдела OASIS

EDEN

Master Collection



OASIS

Caratteristiche strutturali

Structural features / Technische Daten

Caractéristiques techniques / Структурные характеристики

IT

CARATTERISTICHE STRUTTURALI EDEN

STRUTTURA INTERNA DEI MOBILI:

Realizzata con pannelli idrorepellenti di spessore 16 mm, in classe E1 W100, in finitura nera.

STRUTTURA ESTERNA DEI MOBILI:

Realizzata con pannelli di spessore 12 mm, disponibili nelle seguenti finiture:

- Laccato opaco, lucido o metallizzato, per un totale di 74 varianti di colore.
- Legno impiallacciato in 14 varianti.
- Gres porcellanato in 8 varianti
- Vetro colorato lucido, opaco o metallizzato (spessore 5 mm.)
- Vetro colorato cannettato lucido (spessore 5 mm.)

FASCIA SOTTOLAVABO:

Realizzata, di serie, in abbinamento alla finitura scelta per il frontale del mobile.

Su richiesta, senza sovrapprezzo, disponibile in altre finiture del campionario Oasis tra cui oro e cromo lucido.

FRONTALI CASSETTO:

Disponibili nelle seguenti finiture:

- Laccato opaco, lucido o metallizzato, per un totale di 74 varianti di colore.
- Legno impiallacciato in 14 varianti.
- Gres porcellanato in 8 varianti
- Pelle liscia o in versione DELUXE decorata per un totale di 25 varianti
- Vetro colorato lucido, opaco o metallizzato (spessore 5 mm.)
- Vetro colorato cannettato lucido (spessore 5 mm.)

CASSETTI:

Realizzati in metallo in finitura nera.

Nei moduli H. 50cm, il cassetto inferiore è provvisto di sponde rialzate in vetro nero.

I cassetti sono ad estrazione totale, con sistema di auto-chiusura rallentato.

TOP INTEGRATI:

Realizzati in:

- Purefeel: bianco opaco o colorato opaco
- Lightfeel: bianco opaco
- Geacril: bianco lucido
- Corian: bianco opaco
- Gres porcellanato: disponibile in 8 varianti
- Vetro: lucido opaco o metallizzato
- Fenix: disponibile in 8 varianti colore

Top in Marmo: in 14 varianti (da abbinare a lavabo ad incasso sottopiano in ceramica)

LAVABI DA APPOGGIO:

Disponibili in Purefeel bianco opaco o colorato opaco, Lightfeel e ceramica opaca o lucida.

UK

EDEN STRUCTURAL CHARACTERISTICS

INTERNAL STRUCTURE OF THE FURNITURE:

Made from 16mm thick, class E1, W100 water-repellent panels in a black finish.

EXTERNAL STRUCTURE OF THE FURNITURE:

Made from 12mm thick panels available in the following finishes:

- Matt, gloss or metallic lacquer in 74 colour options
- 14 wood veneer finishes
- Porcelain stone in 8 versions
- Coloured glossy, satin or metallic glass (5mm thickness)
- Coloured glossy ribbed glass (5mm thickness)

ACCENT BAND BEHIND DRAWER OPENING:

Finished to harmonise with the chosen finish of the furniture front/s, as standard.

On request, at no extra charge, it may be in other Oasis finishes among them glossy gold and chrome.

DRAWER FRONTS:

Available in the following finishes:

- Matt, gloss or metallic lacquer in 74 colour options
- 14 wood veneer finishes
- Porcelain stone in 8 versions
- Leather in 25 smooth or decorative DELUXE options
- Coloured glossy, satin or metallic glass (5mm thickness)
- Coloured glossy ribbed glass (5mm thickness)

DRAWERS:

Made of metal in a black finish.

In 50cm high versions, the lower drawer is equipped with sides in a black glass finish.

Drawers have full-extension runners with a soft, automatic-close system.

INTEGRATED TOPS:

Finishes:

- Purefeel: matt white or matt coloured
 - Lightfeel: matt white
 - Geacril: glossy white
 - Corian: matt white
 - Porcelain stone: available in 8 types
 - Glass: glossy, matt or metallic
 - Fenix: 8 colour variations available
- Marble Tops: 14 types (to team with a ceramic undercounter basin)

COUNTERTOP BASINS:

Available in matt white or matt coloured Purefeel, Lightfeel and matt or glossy ceramic.

DE

STRUKTURELLE MERKMALE DER KOLLEKTION EDEN

INNERE STRUKTUR DER MÖBEL:

Die innere Struktur besteht aus wasserabweisenden Elementen 16 mm – Klasse E1 W100 in der Ausführung Schwarz.

AUSSENSTRUKTUR DER MÖBEL:

Die innere Struktur besteht aus Elementen – 12 mm – verfügbar in den folgenden Ausführungen:

- Matt, hochglanz oder mit „Metallik Effekt“ lackiert – in 74 Farbvarianten.
- Holz – furniert – in 14 Holzvarianten
- Feinsteinzeug in 8 Varianten
- Glänzendes, farbiges Glas – satiniertes, farbiges Glas – farbiges Glas mit „Metallikeffekt“ – Stärke 5 mm
- Geriffeltes (Ribbed), farbiges, glänzendes Glas – Stärke 5 mm.

UNTERBAUWASCHTISCHBLENDE:

Standardmässig wird es in der gleichen Ausführung der Front realisiert.

Auf Anfrage und ohne Aufpreis, verfügbar auch in anderen Ausführungen unserer Muster – auch in Gold und Chrom.

SCHUBLADENFRONTEN:

Verfügbar in den Ausführungen:

- Matt, hochglanz oder mit „Metallik Effekt“ lackiert, in 74 Farbvarianten.
- Holz – furniert – in 14 Holzvarianten
- Feinsteinzeug in 8 Varianten
- Leder in der Ausführung „glatt“ oder in der dekorierte DELUXE Version in 25 Varianten.
- Glänzendes, farbiges Glas – satiniertes, farbiges Glas – farbiges Glas mit „Metallikeffekt“ – Stärke 5 mm
- Geriffeltes (Ribbed), farbiges, glänzendes Glas – Stärke 5 mm.

SCHUBLADEN:

Realisiert aus Metall in Schwarz

In den Schränken H. 50 cm die untere Schublade ist mit höheren Seitenteilen aus schwarzem Glas realisiert.

Die Schubladen sind mit Vollauszug und gedämpfter Schliessung ausgestattet.

WASCHTISCHE:

Realisiert aus:

- Purefeel: Weiss matt oder Weiss glanz oder gefärbt in matt
 - Lightfeel: Weiss matt
 - Geacril: Weiss hochglanz
 - Corian: Weiss Matt
 - Feinsteinzeug: verfügbar in 8 Varianten
 - Fenix: verfügbar in 8 Varianten
- Abdeckplatte aus Marmor: in 14 Varianten (die Marmorplatte werden zu Unterbauwaschbecken aus Keramik kombiniert)

AUFSATZBECKEN:

Verfügbar aus Purefeel in Weiss matt oder gefärbt in matt – Lightfeel und Keramik (Glanz oder Matt).

FR

CARACTERISTIQUES STRUCTURELLES

STRUCTURE INTÉRIEURE DES MEUBLES:

Fabriquée avec des panneaux hydrofuges de 16 mm d'épaisseur, en classe E1 W100. Finition noire.

STRUCTURE EXTÉRIEURE DES MEUBLES:

Fabriquée avec des panneaux de 12mm d'épaisseur.

Disponibles dans les finitions suivantes:

- Laqué mat, brillant ou métallisé, pour un total de 74 nuances de couleurs.
- Bois plaqué en 14 variétés.
- Grès cérame en 8 variétés.
- Verre coloré brillant, mat ou métallisé de 5mm d'épaisseur.
- Verre coloré côtelé brillant de 5mm d'épaisseur

BANDEAU SOUS-ÉVIER:

Fabriqués, en standard, en combinaison avec la finition choisie pour la façade du meuble.

Sur demande, sans supplément de prix, disponible dans d'autres finitions du nuancier Oasis, l'or et le chrome brillant compris.

FAÇADES DES TIROIRS :

Disponibles dans les finitions suivantes:

- Laqué mat, brillant ou métallisé, pour un total de 74 nuances de couleurs.
- Bois plaqué en 14 variétés.
- Grès cérame en 8 variétés.
- Cuir lisse ou en version DELUXE, décoré, pour un total de 25 variétés.
- Verre coloré brillant, mat ou métallisé de 5mm d'épaisseur.
- Verre coloré côtelé brillant de 5mm d'épaisseur

STRUCTURES DES TIROIRS:

Fabriquées en métal en finition noire.

Dans les modules H. 50cm, le tiroir inférieur est pourvu de côtés surélevés en verre noir.

Les tiroirs sont à extraction totale et équipés d'un système de fermeture ralentie.

PLANS VASQUES INTÉGRÉS:

Fabriqués en:

- Purefeel: blanc mat ou coloré mat.
- Lightfeel: blanc mat
- Geacril: blanc brillant
- Corian: blanc mat
- Grès cérame: disponible en 8 variétés.
- Verre: brillant, mat ou métallisé.
- Fenix: disponible en 8 nuances de couleurs.

Plans en marbre:

disponibles en 14 variétés (à combiner avec un lavabo en céramique à encastrer par-dessous).

VASQUES À POSER:

disponibles en Purefeel blanc mat ou en couleur mat, en Lightfeel et en céramique mate ou brillante.

RU

ТЕХНИЧЕСКИЕ ХАРАКТЕРИСТИКИ КОЛЛЕКЦИИ EDEN

Изделия коллекции выполнены из водоотталкивающих панелей толщиной 16 мм класса E1 W100 черного цвета.

Внешний вид мебели:

Панели толщиной 12 мм доступны в следующих вариантах отделки:

- Лакокрасочная: матовая, глянцевая или металлизированная, 74 цветовых варианта.
- Шпон: 14 вариантов.
- Керамогранит: 8 вариантов
- Стекло (толщина 5 мм.): матовое, глянцевое или металлизированное
- Глянцевое рифленое цветное стекло (толщина 5 мм.)

Панка под раковиной:

В стандартной комплектации сочетается с выбранной отделкой фасада изделия.

По запросу без дополнительной оплаты доступны другие варианты отделки из образцов Oasis, включая золото и полированный хром.

Фасады ящиков:

изготавливаются в следующих вариантах отделки:

- Лакокрасочная: матовая, глянцевая или металлизированная, 74 цвета.
- Шпон: 14 вариантов.
- Керамогранит: 8 вариантов
- Гладкая кожа или с декором DELUXE, 25 вариантов.
- Стекло (толщина 5 мм.): матовое, глянцевое или металлизированное
- Глянцевое рифленое цветное стекло (толщина 5 мм.)

Ящики:

Изготовлен из металла в черном цвете.

В модулях высотой 50 см нижний ящик имеет высокие боковины из черного стекла.

Ящики полностью выдвижные, с системой медленного автоматического закрывания.

Столешницы с интегрированными раковинами изготовлены из следующих материалов:

- Purefeel: матовый композитный камень только белого цвета
- Lightfeel: матовый композитный искусственный камень только белого цвета
- Geacril: глянцевый белый
- Corian: непрозрачный белый
- Керамогранит: 8 вариантах
- Стекло: матовое, глянцевое или металлизированное
- Fenix: 8 цветов.

Мраморная столешница: 14 вариантов

(сочетается с керамическим умывальником, устанавливаемым под столешницу)

Накладные раковины:

Из матового композитного камня только белого цвета Purefeel, Lightfeel или керамики матовой или глянцевой.

Caratteristiche tecniche

Technical characteristics / Technische Daten
 Caractéristiques techniques / Структурные характеристики



Moduli h 30 con 1 cassetto / Modules H 30 with 1 drawer / Module H 30 mit 1 Schublade / Modules de 30cm de hauteur avec 1 tiroir / Тумбы высотой 30 см с 1 ящиком



Moduli h 50 con 2 cassetti / Modules H 50 with 2 drawers / Module H 50 mit 2 Schubladen / Modules de 50cm de hauteur avec 2 tiroirs / Тумбы высотой 50 см с 2-мя ящиками



Moduli h 50 con cassettone e cassetto interno / Modules H 50 with deep drawer and interior drawer / Module H 50 cm mit einer grossen Schublade und Innenschublade / Modules de 50cm de hauteur avec grand-tiroir et tiroir à l'anglaise / Тумбы высотой 50 см с 1 большим ящиком и ящиком внутри

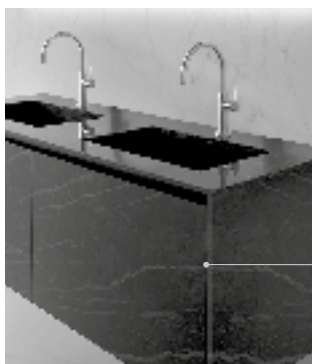

Continuità della venatura tra frontali e fianchi nei mobili in gres

For porcelain stone units the vein continues from the side panels to the fronts. **Gleiche Masserungen der Fronten und Seitenteile für die Möbel aus Feinsteinzeug**
 Continuité des veines entre façades et côtés sur les meubles en Grés cérame
 Непрерывность рисунка прожилок фасада и боковин для тумб в отделке из керамогранита

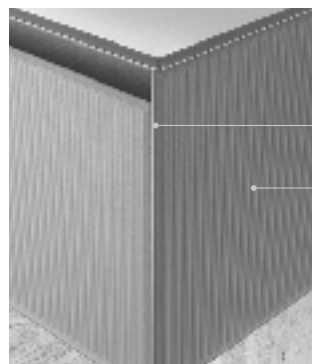

Nuova finitura Ribbed Coloured Glass

New finish Coloured Ribbed Glass
Neue Ausführung "Ribbed" gefärbtes Glas
 Nouvelle finition - Ribbed Coloured Glass
 Новая отделка Стекло цветное рифленое



Possibilità di avere i lavabi in appoggio in ceramica bianca lucida

Countertop basins are available in gloss white ceramic
Aufsatzbecken aus Keramik in Weiss glanz
 Possibilité d'installer des vasques à poser en céramique blanche brillante
 Возможность установки накладных раковин из белой керамики.



Mensole sottolavabo disponibili in finitura laccata o essenza.

Shelves without cut-outs available with a lacquer or wood finish.
Unterwaschtischregale erhältlich in lackierter oder Holzoptik Ausführung.
 Étagères sous-vasque disponibles en finition laquée ou bois.
 Полки под раковиной предлагаются в отделке: лак или дерево.

Modularità

Modularity / Modularität / Modularité / Модульность

H 30 cm - Mobili sospesi / Wall-hung furniture / Hängende Unterschranke / Meubles suspendus / Тумбы навесные

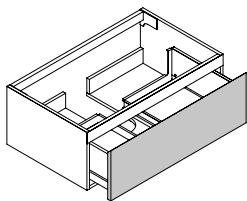

Base portlavabo sospesa con 1 cassetto / Wall mounted vanity with 1 drawer / Waschtischunterschrank mit 1 Schublade / Meuble sous-vasque suspendu avec 1 tiroir / Тумба навесная для раковины с 1 ящиком

W 60/70/80/90/105/120 cm
D 52,5 cm

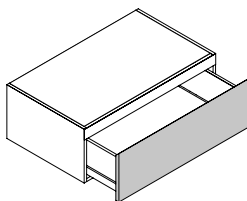

Base complementare sospesa con 1 cassetto / Additional wall-hung base unit with 1 drawer / Hängender Unterschrank mit 1 Schublade / Élément complémentaire suspendu avec 1 tiroir / Тумба боковая с 1 ящиком

W 35/45/60/70/80/90/105/120 cm
D 52,5 cm

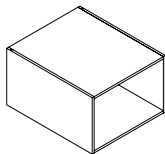

Base complementare sospesa con vano a giorno / Additional wall-hung base unit with open shelf / Hängender Unterschrank mit offenem Regal / Meuble bas suspendu avec compartiment ouvert / Тумба боковая навесная с открытой полкой

W 35/45 cm
D 52,5 cm

H 50 cm - Mobili sospesi / Wall-hung furniture / Hängende Unterschranke / Meubles suspendus / Тумбы навесные

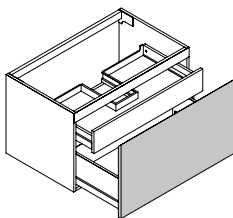

Base portlavabo sospesa con 1 cassetto + cassetto interno / Wall mounted vanity with 1 drawer and 1 inside drawer / Waschtischunterschrank mit 1 Schublade und 1 Innenschublade / Meuble sous-vasque suspendu avec 1 tiroir + 1 tiroir à l'anglaise / Тумба навесная для раковины с 1 ящиком + 1 внутренний ящик

W 60/70/80/90/105/120 cm
D 52,5 cm

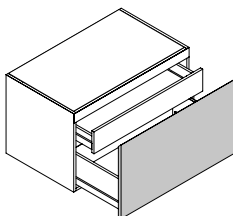

Base complementare sospesa con 1 cassetto + 1 cassetto interno / Additional wall-hung base unit with 1 drawer + 1 interior drawer / Hängende, zusätzliche Möbel mit 1 Schublade und 1 Innenschublade / Meuble complémentaire suspendu avec 1 tiroir + 1 tiroir à l'anglaise / Дополнительная навесная тумба с 1 ящиком + 1 внутренним ящиком

W 35/45/60/70/80/90/105/120 cm
D 52,5 cm

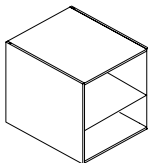

Base complementare sospesa con vano a giorno / Additional wall-hung base unit with open shelf / Hängender Unterschrank mit offenem Regal / Meuble bas suspendu avec compartiment ouvert / Тумба боковая навесная с открытой полкой

W 35/45 cm
D 52,5 cm

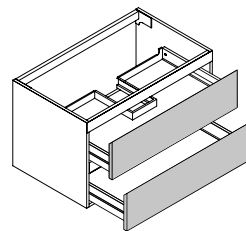

Base portlavabo sospesa con 2 cassetti / Wall mounted vanity with 2 drawers / Waschtischunterschrank mit 2 Schubladen / Meuble sous-vasque suspendu avec 2 tiroirs / Тумба навесная для раковины с 2 ящиками

W 60/70/80/90/105/120 cm
D 52,5 cm

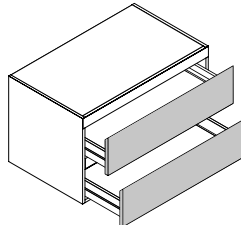

Base complementare sospesa con 2 cassetti / Additional wall-hung base unit with 2 drawers / Hängender Unterschrank mit 2 Schubladen / Élément complémentaire suspendu avec 2 tiroirs / Дополнительный подвесной элемент с 2 ящиками

W 35/45/60/70/80/90/105/120 cm
D 52,5 cm

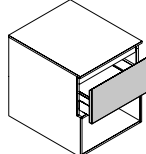

Base complementare sospesa con 1 cassetto e vano a giorno / Additional wall-hung base unit with 1 drawer and open shelf / Hängender Unterschrank mit 1 Schublade und offenem Regal / Meuble bas suspendu avec 1 tiroir et compartiment ouvert / Тумба дополнительная навесная с 1 ящиком и открытой полкой

W 35/45 cm
D 52,5 cm

Modularità

Modularity / Modularität / Modularité / Модульность

H 76 cm - TOP 12 cm Mobili a terra / Free standing vanity units /
Stehende Unterschränke / Meubles au sol / Тумбы напольные

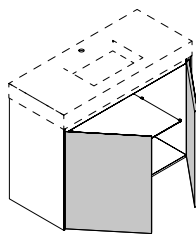

Mobile portalavabo a terra con 2 ante / Freestanding vanity unit with 2 doors / Waschtischunterschränke mit 2 Türen / Meubles sous-vasque au sol avec 2 portes / Тумба для раковины напольная с 2 дверцами

W 90/120
D 52,5 cm

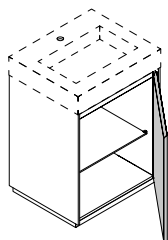

Mobile portalavabo a terra con 1 anta / Freestanding vanity unit with 1 door / Waschtischunterschränke mit 1 Tür / Meubles sous-vasque au sol avec 1 porte / Тумба для раковины напольная с 1 дверцей

W 60
D 52,5 cm

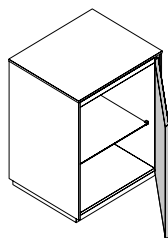

Mobile complementare a terra con 1 anta / Additional freestanding unit with 1 door / Unterschrank mit 1 Tür / Meuble au sol avec 1 porte / Тумба напольная с 1 дверцей

W 35/45/60 cm
D 52,5 cm

H 86 cm - TOP 1,2/2 cm Mobili a terra / Free standing vanity units /
Stehende Unterschränke / Meubles au sol / Тумбы напольные

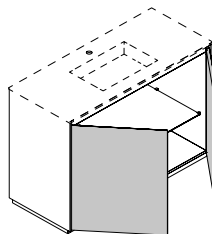

Mobile portalavabo a terra con 2 ante / Freestanding vanity unit with 2 doors / Waschtischunterschränke mit 2 Türen / Meubles sous-vasque au sol avec 2 portes / Тумба для раковины напольная с 2 дверцами

W 90/120
D 52,5 cm

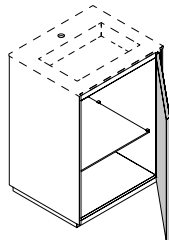

Mobile portalavabo a terra con 1 anta / Freestanding vanity unit with 1 door / Waschtischunterschränke mit 1 Tür / Meubles sous-vasque au sol avec 1 porte / Тумба для раковины напольная с 1 дверцей

W 60
D 52,5 cm

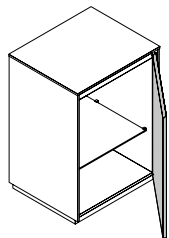

Mobile complementare a terra con 1 anta / Additional freestanding unit with 1 door / Unterschrank mit 1 Tür / Meuble au sol avec 1 porte / Тумба напольная с 1 дверцей

W 35/45/60 cm
D 52,5 cm

Modularità

Modularity / Modularität / Modularité / Модульность

H 80/120/162 /196* cm - Colonne "Cube" con sistema di apertura push-pull / "Cube" Tall Units with push-pull opening system / Hochschrank „Cube“ mit Push-Pull System / Colonne "Cube" avec système d'ouverture push-pull / Колонны Cube с системой открывания push-pull

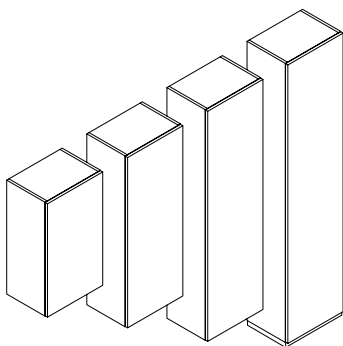

Colonne sospese / Wall-hung tall units / Hängende Hochschränke / Colonne suspendues / Навесные колонны

W 35/45/70/90 cm

D 25/35 cm

H 80/120/162 /196* cm - Colonne "Cube" con maniglia / Colonne "Cube" con maniglia / "Cube" Tall Units with handle / Hochschrank „Cube“ mit Griff / Colonne "Cube" avec poignée / Колонны Cube с ручкой

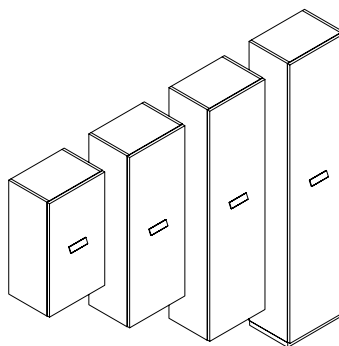

Colonne sospese / Wall-hung tall units / Hängende Hochschränke / Colonne suspendues / Навесные колонны

W 35/45/70/90 cm

D 25/35 cm



MAURÌ



HOLY

Maniglie / Handles / Handgriffe / Poignées / Ручки

Disponibil in 2 finiture: nero e bronzo / Available in 2 Finishes : black and bronze / Ausführung in 2 Varianten: Schwarz und Bronze / Disponibles en 2 finitions: noir et bronze / Поставляются в 2-х видах отделки: черной и бронзовой

H 80/120/162 /196* cm - Colonne "Alu" con anta telaio in alluminio nero / "Alu" Tall Unit with door frame in black aluminum / Hochschrank „Alu“ mit schwarzem Rahmen aus Aluminium / Colonne « Alu » avec porte à cadre en aluminium noir / Колонна Alu с дверцей в алюминиевом профиле матового черного цвета

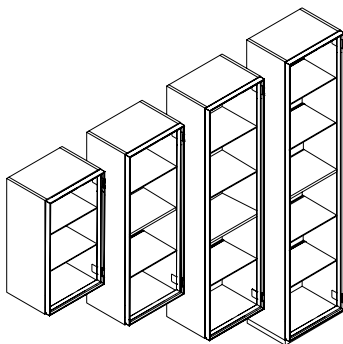

Colonne sospese / Wall-hung tall units / Hängende Hochschränke / Colonne suspendues / Навесные колонны

W 35/45/70/90 cm

D 25/35 cm

H 80/120/162 /196* cm - Colonne "Max" con anta a sbalzo / "Max" Tall Unit with overhang door / Hochschrank „Max“ mit überstehender Tür / Colonne « Max » avec porte en porte-à-faux / Колонна Max с распашной дверцей

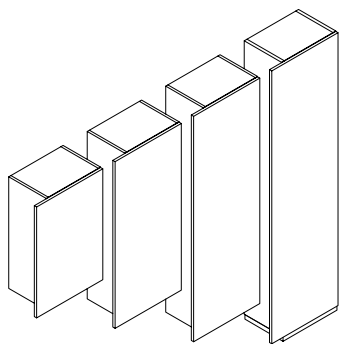

Colonne sospese / Wall-hung tall units / Hängende Hochschränke / Colonne suspendues / Навесные колонны

W 45 cm

D 25/35 cm

***Le colonne con altezza 196 cm a terra, sono complete di zoccolo. Nella larghezza 70/90 cm la colonna è realizzata con 2 ante.**

*The freestanding tall units 196 cm tall, do have an included plinth. In the 70/90 cm wide version, the tall unit is realized with two doors.

*Die Hochschränke in der Höhe 196 cm sind mit Sockel ausgestattet. In der Länge 70/90 cm ist der Hochschrank mit 2 Türen ausgestattet.

*Les colonnes au sol d'une hauteur de 196cm sont fournies avec socle. Dans la largeur 70/90cm, la colonne est fournie avec 2 portes.

*Колонны напольные высотой 196 см поставляются в комплекте с цоколем. При длине 70/90 см колонны поставляются с 2 дверцами.

Modularità

Modularity / Modularität / Modularité / Модульность

H 162 cm - Colonne sospese / Wall-hung tall units / Hängende Hochschränke / Colonnes suspendues / Навесные колонны

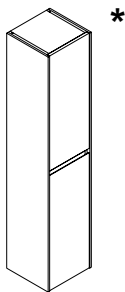

W 32 cm
D 32 cm

H 80/120/162 /196* cm - Colonne sospese con vano a giorno / Wall-hung tall units with open compartment / Hängende Hochschränke mit offenem Regalteil / Colonnes suspendues avec compartiment ouvert / Колонны подвесные с открытой полкой

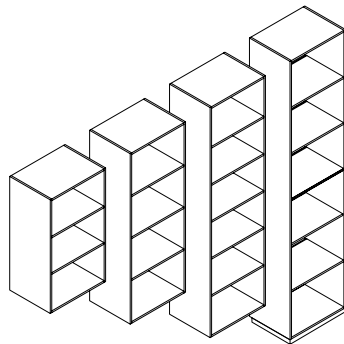

W 35/45 cm
D 25/35 cm

Boiserie "RIGA" su misura / Boiserie custom made "RIGA" / Wandverkleidung „Riga“ auf Mass / Boiserie "Riga" sur mesure / Буазери Riga по индивидуальному размеру

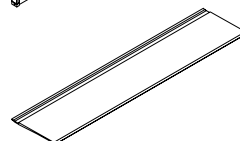
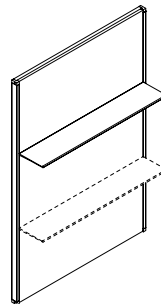

Mensole / Shelves / Ablagen / Étagères / Полки
W 30/60/75/90/120

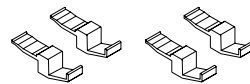

Set 4 ganci / 4 hooks set / 4 Haken / Set de 4 crochets / Комплект из 4-х крючков

H 80 cm - PENSILI / Wall units / Hängeschränke / Éléments hauts / Модули навесные

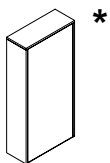

Pensile 1 ante / 1 door Wall units / Hängeschränk mit 1 Tür / Éléments hauts 1 porte / Модули навесные с 1 дверцей

W35 X D15 cm

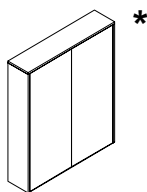

Pensili 2 ante / 2 doors Wall Units / Hängeschränke mit 2 Türen / Éléments hauts avec 2 portes / Модуль навесной с 2 дверцами

W70 X D15 cm



Pensile a giorno in vetro fumè / Open shelf wall unit with smoked glass / Regal aus Glas in der Ausführung Fumé / Élément haut ouvert en verre fumé. / Модуль навесной с открытой полкой в отделке из затемненного стекла

W35 X D15 cm



Pensile a giorno in vetro fumè / Open shelf wall unit with smoked glass / Regal aus Glas in der Ausführung Fumé / Élément haut ouvert en verre fumé. / Модуль навесной с открытой полкой в отделке из затемненного стекла

W50 X D15 cm

***Le colonne con altezza 196 cm a terra, sono complete di zoccolo. Tutte le misure indicate non includono i fianchi di finitura che dovranno essere aggiunti.**

*The freestanding tall units 196 cm tall, do have an included plinth. All the shown measures do not include the finishes side panels, which will need to be added.

*Die Hochschränke in der Höhe 196 cm sind mit Sockel ausgestattet. Die angegebenen Massen verstehen sich exklusive der Seitenteile, die noch zusätzlich kalkuliert werden müssen.

*Les colonnes au sol d'une hauteur de 196cm sont fournies avec socle. Toutes les mesures indiquées n'incluent pas les côtés de finition, qui devront être ajoutés.

*Колонны напольные высотой 196 см поставляются в комплекте с цоколем. Все указанные габариты не включают отделочные боковины, которые необходимо будет добавить

Note importanti

Important notes / Wichtige Hinweise
Notes importantes / Важные примечания

Per ragioni di componibilità nella collezione Eden devono sempre essere ordinati anche i fianchi di finitura.

For modularity purposes, for the Eden collection it is important to order end finishing panels.

Aus Grund der Modularität der Kollektion Eden müssen die Abschluss-Seitenteile immer zusätzlich bestellt werden.

Pour des raisons de modularité, dans la collection Eden les côtés de finition doivent toujours être commandés.

По причинам модульной концепции, в коллекции Eden необходимо всегда также заказывать отделочные боковины.

FIANCHI DI FINITURA PER COMPOSIZIONI CON ELEMENTI SINGOLI

Nella Collezione Eden, i fianchi di finitura vanno ordinati in base alla composizione finale dei moduli. Nel caso in cui la composizione sia formata da un elemento singolo l'ordine dovrà comprendere anche i due fianchi di finitura.

END FINISHING PANELS FOR ARRANGEMENTS WITH SINGLE ELEMENTS

For the Eden collection, end finishing panels must be ordered as needed depending on the final arrangement of the modules.

If the arrangement is made up of just one element, the order must include two end finishing panels.

CÔTÉS DE FINITION POUR COMPOSITIONS AVEC ÉLÉMENTS SIMPLES

Dans la Collection Eden, les côtés de finition doivent être commandés en fonction de la composition finale des modules. Si la composition consiste en un seul élément, la commande doit également inclure les deux côtés de finition.

БОКОВИНЫ ДЛЯ КОМПОЗИЦИЙ С ЕДИНИЧНЫМИ ЭЛЕМЕНТАМИ

В коллекции Eden, отделочные боковины должны быть заказаны в соответствии с окончательной композицией модулей. В случае, если композиция сформирована из единичного элемента, в заказе должны быть 2 отделочные боковины.

ABSCHLUSS-SEITENTEILE FÜR ZUSAMMENSTELLUNGEN MIT EINZELEMENTEN

Bei der Eden-Kollektion müssen die Abschluss-Seitenteile je nach endgültigen Zusammensetzung der Module bestellt werden. Besteht die Zusammensetzung aus einem einzigen Element, müssen auch die beiden Abschluss-Seitenteile bestellt werden.

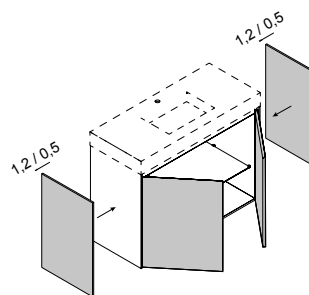
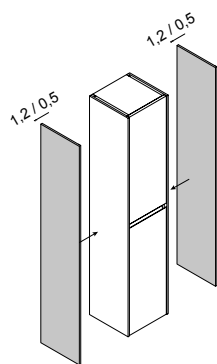

FIANCHI DI FINITURA PER COMPOSIZIONI CON ELEMENTI ACCOSTATI DI UGUALE ALTEZZA

Nel caso in cui sia abbiano composizioni con elementi accostati di uguale altezza, dovranno essere ordinati, solo i due fianchi di finitura esterni, indipendentemente dal numero di elementi accostati.

END FINISHING PANELS FOR ARRANGEMENTS WITH UNITS OF THE SAME HEIGHT FITTED SIDE BY SIDE

Arrangements composed of elements of the same height require only two end finishing panels, regardless of the number of units fitted side by side in the arrangement.

CÔTÉS DE FINITION POUR COMPOSITIONS COMPRENANT DES ÉLÉMENTS DE HAUTEUR ÉGALE

S'ils sont des compositions avec des éléments d'égale hauteur, doivent être commandés les deux côtés de finition externes uniquement, quel que soit le nombre d'éléments assemblés.

ОТДЕЛОЧНЫЕ БОКОВИНЫ ДЛЯ КОМПОЗИЦИЙ С ПРИМЫКАЮЩИМИ ЭЛЕМЕНТАМИ ОДИНАКОВОЙ ВЫСОТЫ

В случае, если композиция идет с примыкающими элементами одинаковой высоты, должны быть заказаны только 2 внешние боковины, вне зависимости от количества элементов.

ABSCHLUSS-SEITENTEILE FÜR ZUSAMMENSETZUNGEN MIT NEBENEINANDER AUFGESTELLTEN ELEMENTEN MIT GLEICHER TIEFE UND HÖHE

Bei Zusammenstellungen mit nebeneinander aufgestellten Elementen mit gleicher Höhe und Tiefe müssen nur die Abschluss-Seitenteile bestellt werden, unabhängig von der Anzahl der Elemente, die nebeneinander aufgestellt werden.

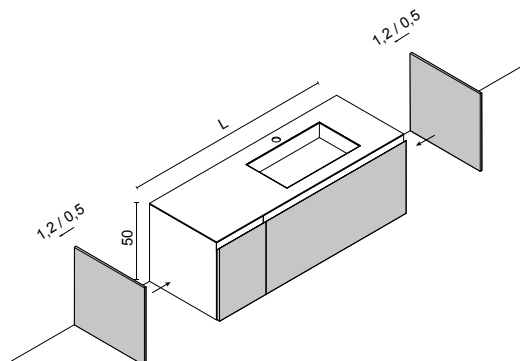

Per ragioni di componibilità nella collezione Eden devono sempre essere ordinati anche i fianchi di finitura.

For modularity purposes, for the Eden collection it is important to order end finishing panels.

Aus Grund der Modularität der Kollektion Eden müssen die Abschluss-Seitenteile immer zusätzlich bestellt werden.

Pour des raisons de modularité, dans la collection Eden les côtés de finition doivent toujours être commandés.

По причинам модульной концепции, в коллекции Eden необходимо всегда также заказывать отделочные боковины.

FIANCHI DI FINITURA PER COMPOSIZIONI CON ELEMENTI ACCOSTATI DI DIVERSA ALTEZZA

Nel caso in cui si abbiano composizioni con elementi accostati di diversa altezza, dovranno essere ordinati, oltre ai due fianchi di tamponamento esterni alla composizione (1), anche gli eventuali fianchi di tamponamento interni alla composizione stessa (2).

END FINISHING PANELS FOR ARRANGEMENTS WITH UNITS OF DIFFERENT HEIGHTS FITTED SIDE BY SIDE

In the event of arrangements containing units of different heights, as well as the two end finishing panels (1), side panels for intermediate units in the arrangement (2) may also be required.

ABSCHLUSS-SEITENWÄNDE FÜR ZUSAMMENSETZUNGEN MIT NEBENEINANDER AUFGESTELLTEN ELEMENTEN MIT GLEICHER TIEFE UND UNTERSCHIEDLICHEN HÖHE

Bei Zusammenstellungen mit nebeneinander aufgestellten Elementen mit gleicher Tiefe aber unterschiedlicher Höhe müssen neben den beiden äusseren Seitenwänden der Zusammenstellung (1) auch noch die eventuellen Passleisten (2) für die durch die Höhendifferenz freiliegenden Teile bestellt werden, unabhängig von der Anzahl der Elemente, die nebeneinander aufgestellt werden.

CÔTÉS DE FINITION POUR COMPOSITIONS COMPRENANT DES ÉLÉMENTS DE DIFFÉRENTES HAUTEURS

S'ils sont des compositions avec des éléments joints de hauteurs différentes, en plus des deux côtés de finition externes à la composition (1) on devra commander tous les côtés de finition à l'intérieur de la composition (2).

ОТДЕЛОЧНЫЕ БОКОВИНЫ ДЛЯ КОМПОЗИЦИЙ С ПРИМЫКАЮЩИМИ ЭЛЕМЕНТАМИ РАЗНОЙ ВЫСОТЫ

В случае, если композиция идет с примыкающими элементами разной высоты, должны быть заказаны, помимо двух внешних боковин (1), также соответствующие внутренние боковины (2)

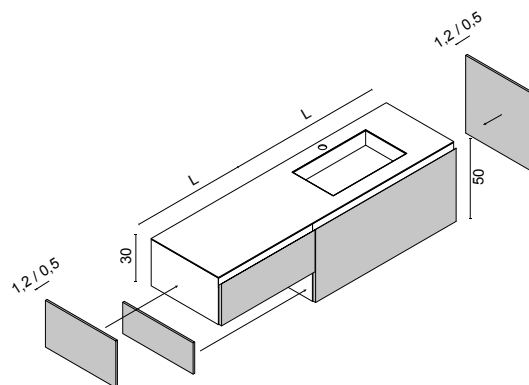

Finiture collezione Eden

Eden collection furniture finishes / Möbelausführungen der Kollektion Eden
 Finitions des meubles de la collection Eden / Отделка мебели в коллекции Eden

<p>CAT. 1</p> <p>M Laccato opaco Matt lacquered / Matt lackiert / Laqué mat Лак матовый</p>	<p>CAT. 2</p> <p>G Laccato lucido Gloss lacquered / Glanz lackiert / Laqué brillant Лак глянецовый</p>
<p>CAT. 3</p> <p>VL Vetro colorato lucido Gloss lacquered glass / Glas glanz / Verre coloré brillant / Стекло цветное глянецовое</p> <p>E Essenza Wood / Holz / Bois / Шпон</p> <p>E0006 Sand Oak E0022 White Chestnut E0023 Grey Chestnut E0025 Black Chestnut E0027 Charcoal Oak E0024 Hemp Chestnt</p>	<p>CAT. 4</p> <p>D Laccato metallizzato lucido Glossy metallic lacquered / Lackiert in Metal likfarbe glanz / Laqué métallisé brillant / Лак металлизированный глянецовый</p> <p>VS Vetro colorato satinato Satin lacquered glass / Glas satiniert Verre coloré satiné / Стекло цветное Сатинированное</p> <p>E Essenza Wood / Holz / Bois / Шпон</p> <p>E0012 Walnut E0026 Heat Treated Oak E0028 Eucalyptus</p>
<p>CAT. 5</p> <p>VD Vetro colorato metallizzato Metallic lacquered glass / Glas "Metallic" Verre coloré métallisé / Стекло цветное металлизированное</p> <p>E Essenza Wood / Holz / Bois / Шпон</p> <p>EP001 Ammara Ebony EP002 Makassar EP003 Dark Mahogany E0019 Oak Carved E0020 Walnut Carved</p>	<p>CAT. 6</p> <p>VR Vetro colorato cannettato Colored ribbed glass / Geriffeltes, farbiges Glas Verre cannelé coloré / Стекло рифленое цветное</p> <p>VM Vetro cannettato colorato metallizzato Metallic colored ribbed glass / Geriefeltes, farbiges Glas in den Metallic Färben / Verre cannelé en cou- leur métallisé / Стекло Ribbed металлизированная отделка</p> <p>LG Gres porcellanato Porcelain stone / Feinsteinzeug Grés cérame / Керамогранит</p>
<p>CAT. 7</p> <p>P Pelle liscia Plain Leather / Glattes Leder / Cuir lisse / Кожа гладкая</p> <p>R Pelle Deluxe Leather print deluxe / Leder Variante „Deluxe“ / Impression cuir de luxe / Кожа с течением Deluxe</p>	

CAT. = Categoria di prezzo / Price category / Preiskategorie / Catégorie de prix / Категория цены

Abbinamento finitura mobile - finitura fascia

Matching unit finish - band finish / Kombination Ausführung Möbel - Ausführung des Bandes
 Combinaison finition du meuble - finition de la bande / Сочетание с отделкой тумб - отделка планки

Finitura mobile Finish of unit / Ausführung des Möbels Finition du meuble / Отделка мебели		Finiture fascia Finish of the trim / Ausführung des Unterbauwaschtischbandes Finition du bandeau / Отделка планки	
		di serie / standard / Serienmäßig en standard / стандарт	su richiesta / on request / Auf Anfrage sur demande / по запросу
M	Laccato opaco Matt lacquered / Matt lackiert / Laqué mat / Лак матовый	<p>abbinata alla finitura del mobile matching the finish of the unit Kombiniert in der gleichen Ausführung des Möbels / Combinée à la finition du meuble / сочетается с отделкой мебели</p> <p>cromo lucido polished chrome / Chrom glanz Chrome brillant / хром блестящий</p> <p>oro lucido Gloss Gold / Gold glanz Or brillant / Золото блестящее</p> <p>le finiture su richiesta non hanno sovrapprezzo the finishes available on request do not have a surcharge / Die Ausführungen auf Anfrage ohne Aufpreis / Les finitions sur demande n'ont pas une majoration de prix / Отделка по запросу без повышения стоимости</p>	
G	Laccato lucido Gloss lacquered / Glanz lackiert / Laqué brillant / Лак глянцевый		
D	Laccato metallizzato lucido Glossy metallic lacquered / Lackiert in Metal likfarbe glanz / Laqué métallisé brillant / Лак металлизированный глянцевый		
E	Essenza Wood / Holz / Bois / Шпон		
VL	Vetro colorato lucido Gloss lacquered glass / Glas glanz Verre coloré brillant / Стекло цветное глянцевое		
VS	Vetro colorato satinato Satin lacquered glass / Glas satiniert Verre coloré satiné Стекло цветное Сатинированное		
VD	Vetro lucido metallizzato Metallic lacquered glass / Glas "Metallic" / Verre coloré métallisé / Стекло цветное металлизированное		
VM	Vetro cannettato colorato metallizzato Colored ribbed glass / Geriffeltes, farbiges Glas Verre cannelé coloré / Стекло рифленое цветное		
VR	Vetro colorato cannettato Colored ribbed glass / Geriffeltes, farbiges Glas / Verre cannelé coloré / Стекло рифленое цветное		
LG	Gres porcellanato Porcelain stone / Feinsteinzeug Grés cérame / Керамогранит		
P	Pelle liscia Plain Leather / Glattes Leder / Cuir lisse / Кожа гладкая		
R	Pelle Deluxe Leather print deluxe / Leder Variante „Deluxe“ / Impression cuir de luxe / Кожа с течением Deluxe		