

*Plissé*



**OASIS**

**LUXURY  
COLLECTION**

Oasis offers so much more than a selection of furniture. Indeed, the company aims to propose a complete and coordinated interior design, inspired by an idea: the beauty of the 1900s. Nevertheless Oasis also looks at the decades of great Italian design and architecture to capture the secret of blending different raw materials in a new, unique and universal design.



# Oasis, a story in time



**1908**

Floriano Quaia opens his first carpentry workshop: a small studio where furniture is made with the aim of lasting a lifetime.



**1945**

Bernardo Quaia, son of Floriano, sets down the foundations of a company where the first pieces of decorative furniture would later be developed.



**1972**

Francesco, Bernardo's son, builds a factory and creates - using his surname - an actual brand. Together with his brother Floriano, he sets up Arredamenti Quaia.



**1980**

Arredamenti Quaia participates in the Salone del Mobile, Milan for the very first time. The accompanying burst of innovation marks a turning point for the company which sets its sights on ever broader horizons.



**1984**

During the flurry of the Eighties, Francesco Quaia establishes the Oasis brand, branching out into the production of bathroom furniture which thereafter becomes part of the company offer.

**2012**

The Home line is completely revised and relaunched with the aim of offering, under the Oasis label, a complete and coordinated luxury interiors package inspired by the language of cosmopolitan and contemporary style.



**The New Millennium**

At the turn of the Millennium, an impetus of change, of fresh new ideas, sweeps through the company in the form of the next generation, Francesco's three children: Francesca, Federica and Lorenzo.



**Nowadays**

The company is a century-old family business characterised by courage, tradition and a strong identity. It has market presence in more than 25 countries, the main ones being: Russia, Ukraine, the United Kingdom, Germany, France, Switzerland, Belgium and the United States. The Oasis production portfolio includes a wide range of furniture collections for the Home, the Bathroom and the Contract industry for the construction of projects for both residential and professional purposes.

**2013**

The year sees monobrand flagship showrooms opening in both London and Hong Kong.

## The future of italian know-how.

There is only one area of Italy where the air can blow in from foreign lands, that place is Friuli. And along with that wind comes history, style and certain ways of thinking. It is here that the story of Oasis began, the result of a refined and eclectic merging of different cultures, civilisations, languages and cuisines often referred to around the world as "Italian style".

### Francesca Quaia

The eldest, Francesca, is the first to work alongside her father in the business. By assuming responsibility in 2001 for the commercial direction of the company, is pivotal in steering it along the road to internationalisation.

### Federica Quaia

Second daughter Federica, having specialised in the worldwide branding of luxury goods, takes over all aspects of image and communication within the company in 2006, thus assuming marketing and artistic control.

### Lorenzo Quaia

Third-born Lorenzo completes the transition to the fourth generation in 2008. Specialising in project research and development as well as highly technical products, he becomes head of the technical production division.



Essential, but sumptuous and elegant thanks to its delicate workmanship, the basin column Plissé draws its inspiration from the dense folding that allows to give body to the fabrics, at the same time leaving them free to flutter, underlining their movement.

So is the basin column Plissé, with its important shape resembling a classical sculpture, lightened by the folding like an accordion, which creates an ideal movement, like temples of Greek architecture. Just like an ancient peplum, the basin column Plissé, made of white ceramic, has a ring decorating in gold or chrome metal, almost to underline the "waist", as in a high fashion dress.

Oasis, the Italian company with the widest offer of contemporary luxury bathroom furnishing, is always attentive to the evolution of style, and Plissé confirms this.

Thanks to its simple and precious elegance, Plissé fits perfectly in luxurious ambients, characterized by rigorous projects, with a particular attention to the details of interior architecture.

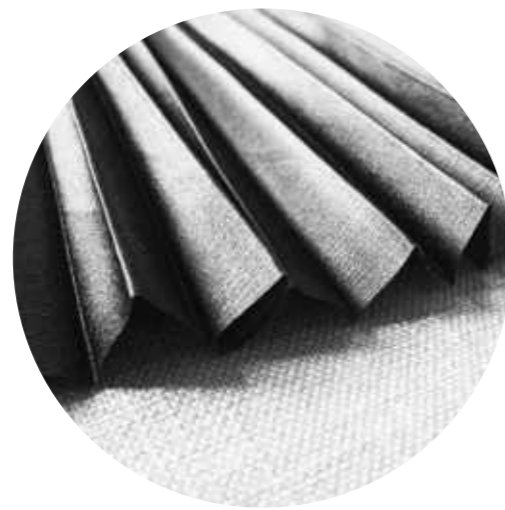

*Plissé*



# Inspirational Design

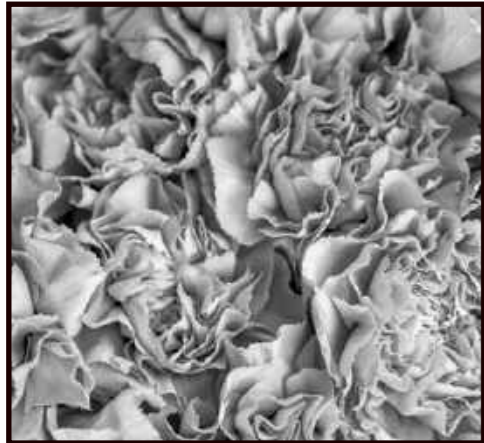
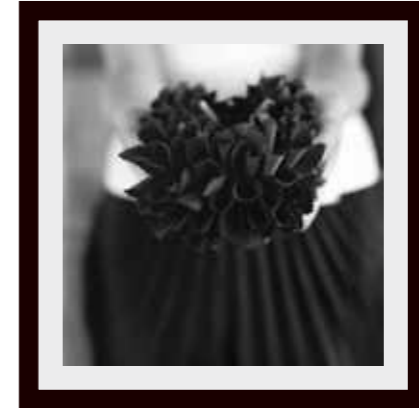
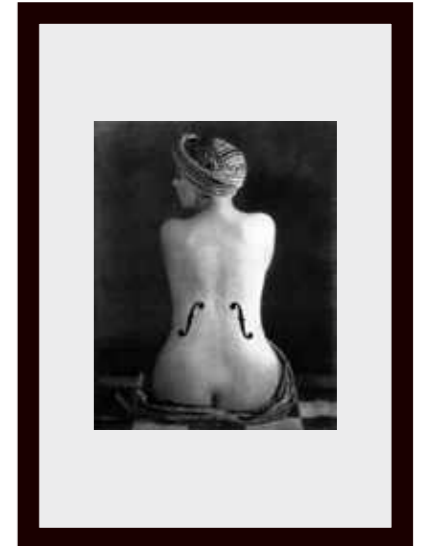



## PLISSE' PL1

Ø44 x H95 cm

**Free-standing Washbasin Version**

**Finishes:** White ceramic with ring in gold finish.

**Suspended Lamp:** STRADIVARI, triple unit version; **Tap:** DRESSCODE in gold metal finish;

**Accessories:** SQUARE towel holder in gold metal finish.

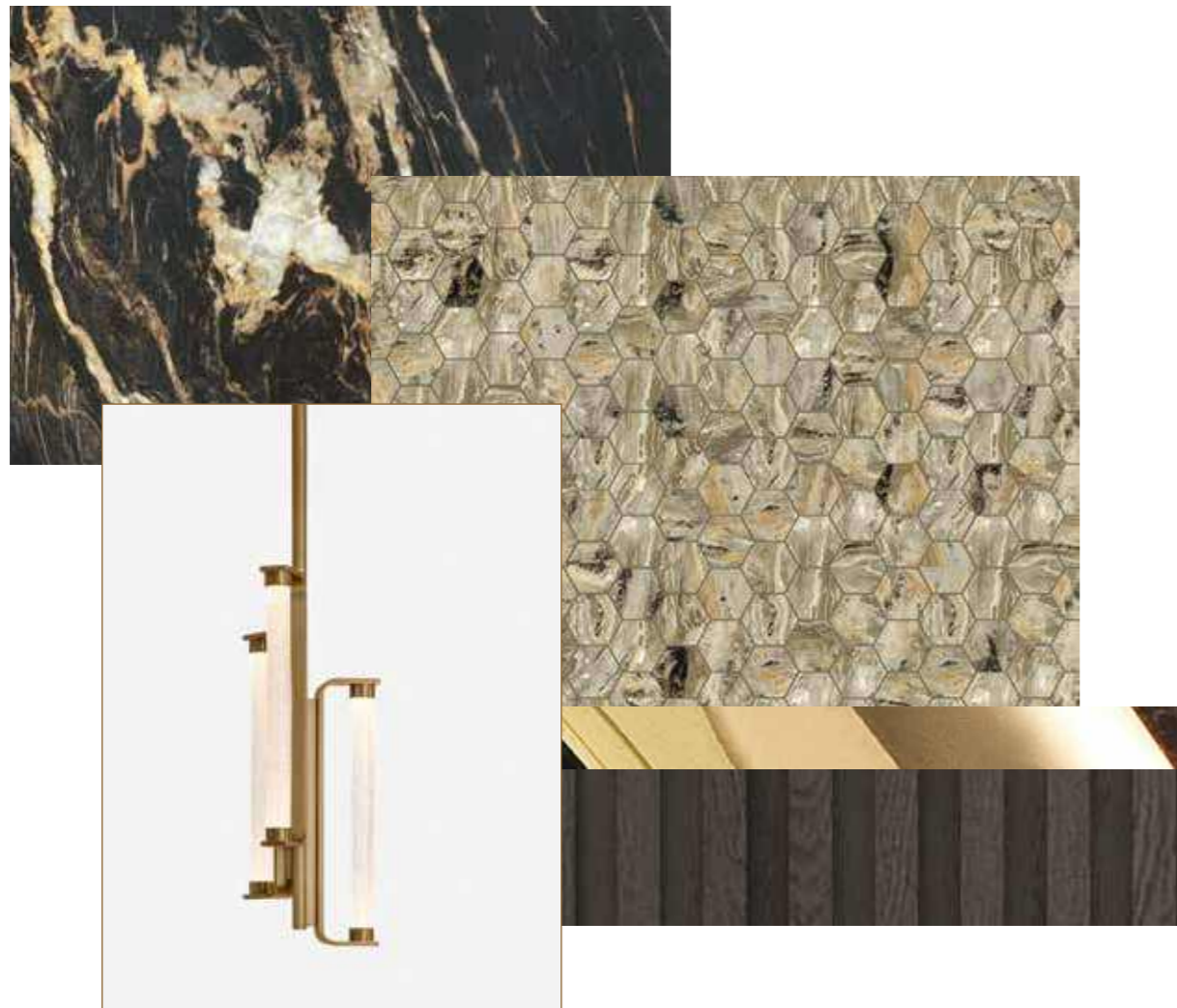

**STRADIVARI**  
Suspended Lamp - Triple Unit

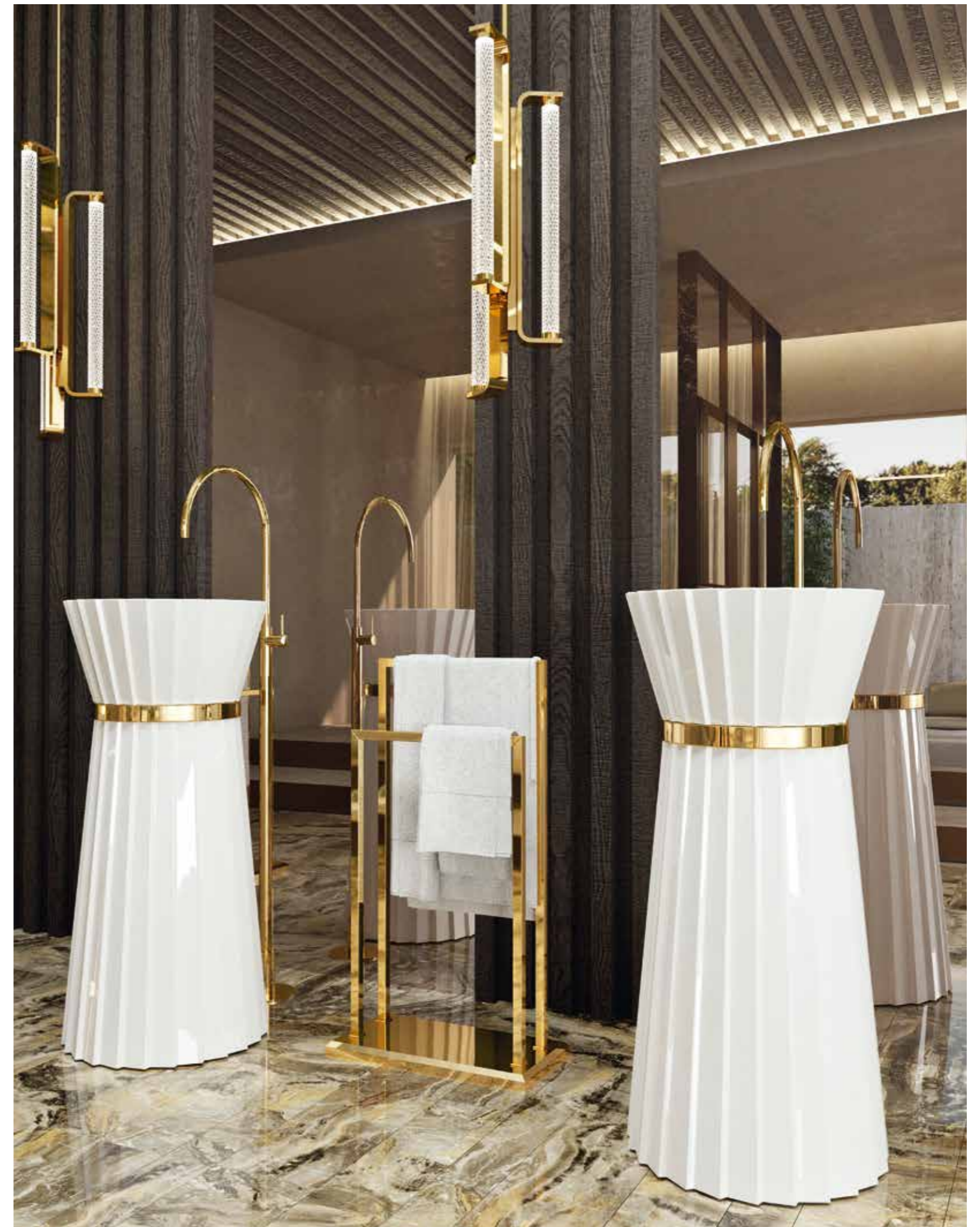







**DÉFILÉ**  
ACCESSORIES  
Knurled gold metal finish



**SULLIVAN**  
SIDE TABLES  
Bronze lacquered finish



**DUCALE FLUTE**  
DOWN VERSION  
Kube glass decoration,  
gold metal structure





**EROS**  
SIDE TABLES  
Glossy Avorio finish  
Bronze lacquered finish



**EDGE SMALL**  
WALL LAMP  
Light Gold, Dark Gold, Walnut





*Personalization*

CERAMIC DECORATIVE RING  
IN DIFFERENT FINISHES.



**0PI440CEBI**  
White



**0PI440CEOR**  
Gold



**0PI440CECR**  
Chrome





*Dressing Black*

BLACK CERAMIC WITH RING IN DIFFERENT FINISHES.





**DUCALE SPHERE**  
UP VERSION  
Smooth glass decoration,  
gold metal structure



**DÉFILÉ**  
ACCESSORIES  
Knurled gold metal finish

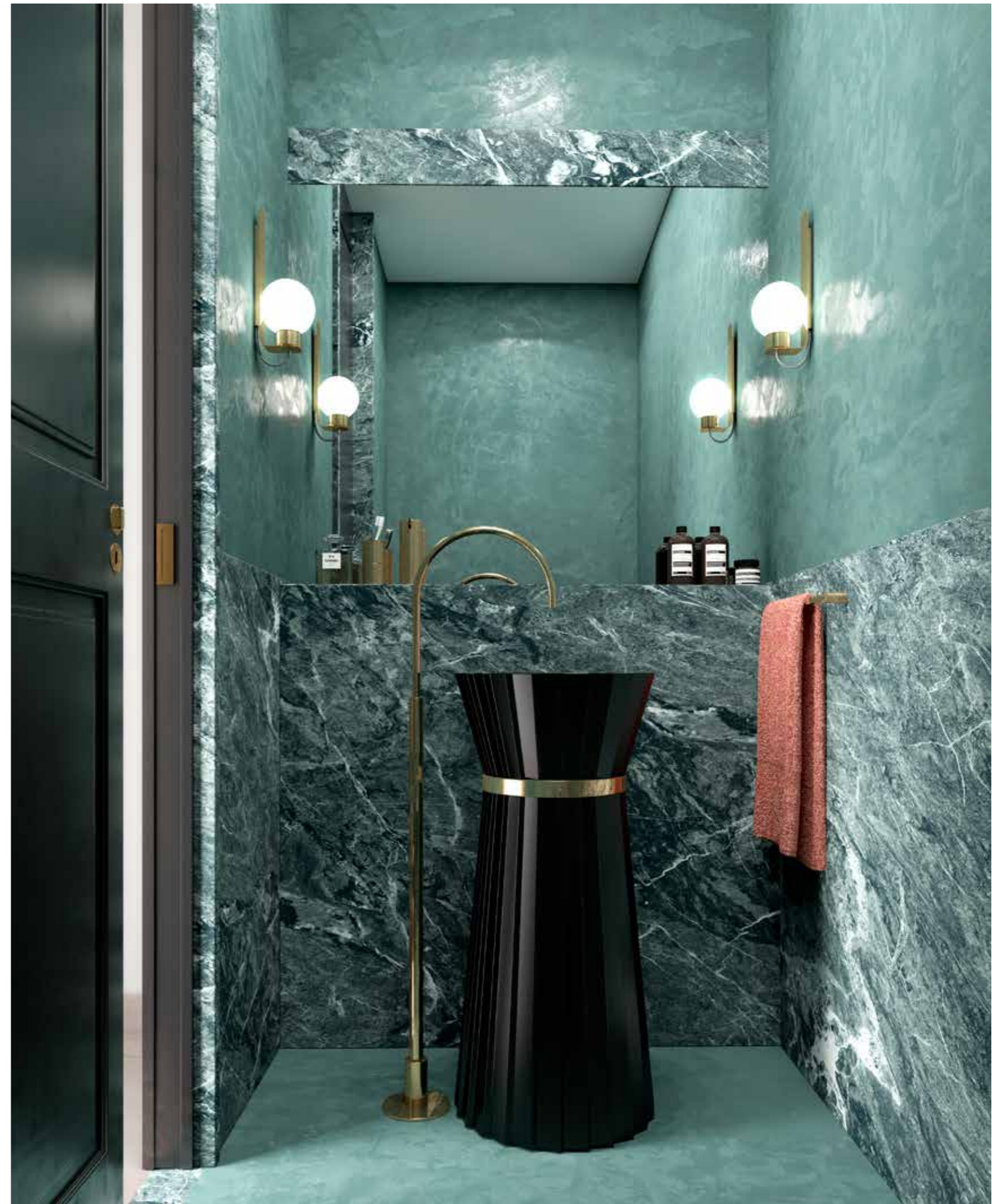



Fashion and Design  
continue to captivate new  
generations thanks to  
classic nuances which are  
always in vogue.



*Plissé*  
COUNTERTOP WASHBASIN





# PLISSÉ

## COUNTERTOP WASHBASIN PERSONALIZATION

**L66 x W46 x H16 cm**

**Finishes:** White ceramic with ring in different finishes.



**0PILAOVB13**  
white



**0PILAOVB LOR3**  
gold



**0PILAOVB LCR3**  
chrome







**DUCALE SPHERE**  
DOWN VERSION  
Rhombus glass decoration,  
gold metal structure



**CHARLOTTE**  
FAUCET  
Gold metal finish / amber finish





**MEDEA**  
SIDE TABLE  
Avorio finish and  
bronze metal frame

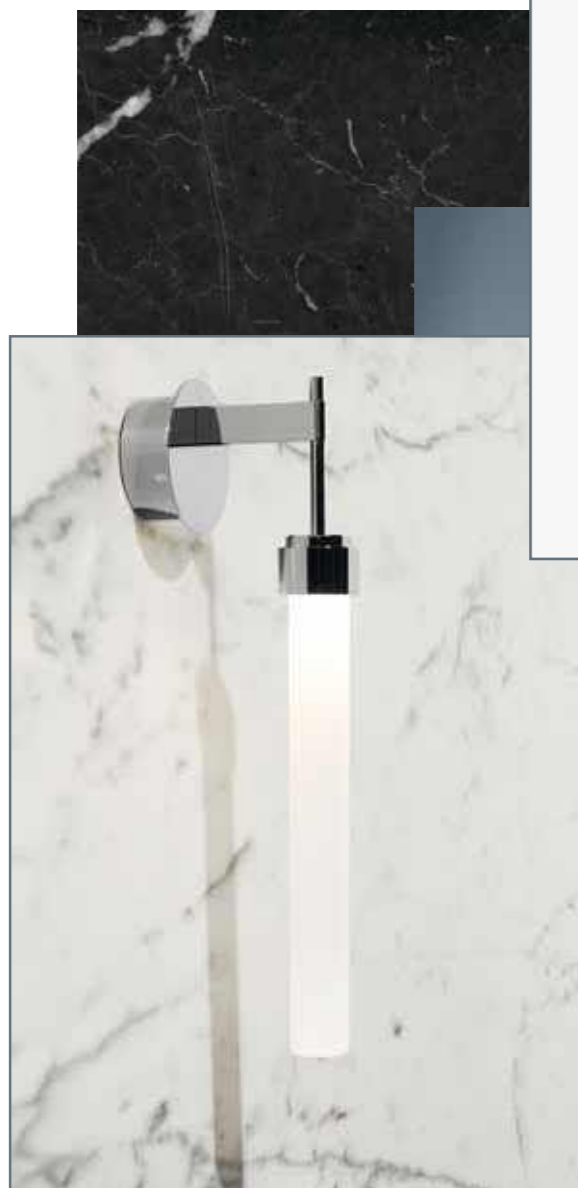

**DUCALE FLUTE**  
DOWN VERSION  
Smooth glass decoration,  
chrome metal structure





## DAPHNE D33

L124 x W52,5 x H220 cm

**Finishes:** smoke mirror. Square handles in chrome metal finish.

**Washbasin & Top:** smoke mirror top. PLISSE' countertop washbasins in white ceramic with ring in chrome finish.

**Mirror:** NARCISO, 70 x 4 x 110 cm; **Wall Lamp:** STRADIVARI, single unit; **Tap:** VENICE in chrome metal finish;

**SQUARE Accessories:** towel holder, toothbrush holder, soap dispenser and mirror.



**SQUARE**  
ACCESSORIES  
Chrome metal finish

**STRADIVARI**  
WALL LAMP  
Decorative glass and  
chrome metal structure







## DAPHNE D30

L194 x W52,5 x H220 cm

**Finishes:** DP01 metallic Prosecco finish. Oval handles in gold metal finish.

**Washbasin & Top:** VDP1 metallic Prosecco glass top. PLISSE' countertop washbasins in white ceramic with ring in gold finish.

**Mirror:** LONDON, 70 x 3 x 100 cm; **Wall Lamp:** STRADIVARI, single unit; **Tap:** VENICE in gold metal finish.

**VENICE  
FAUCET**  
Gold metal finish



**SQUARE  
ACCESSORIES**  
Gold metal finish

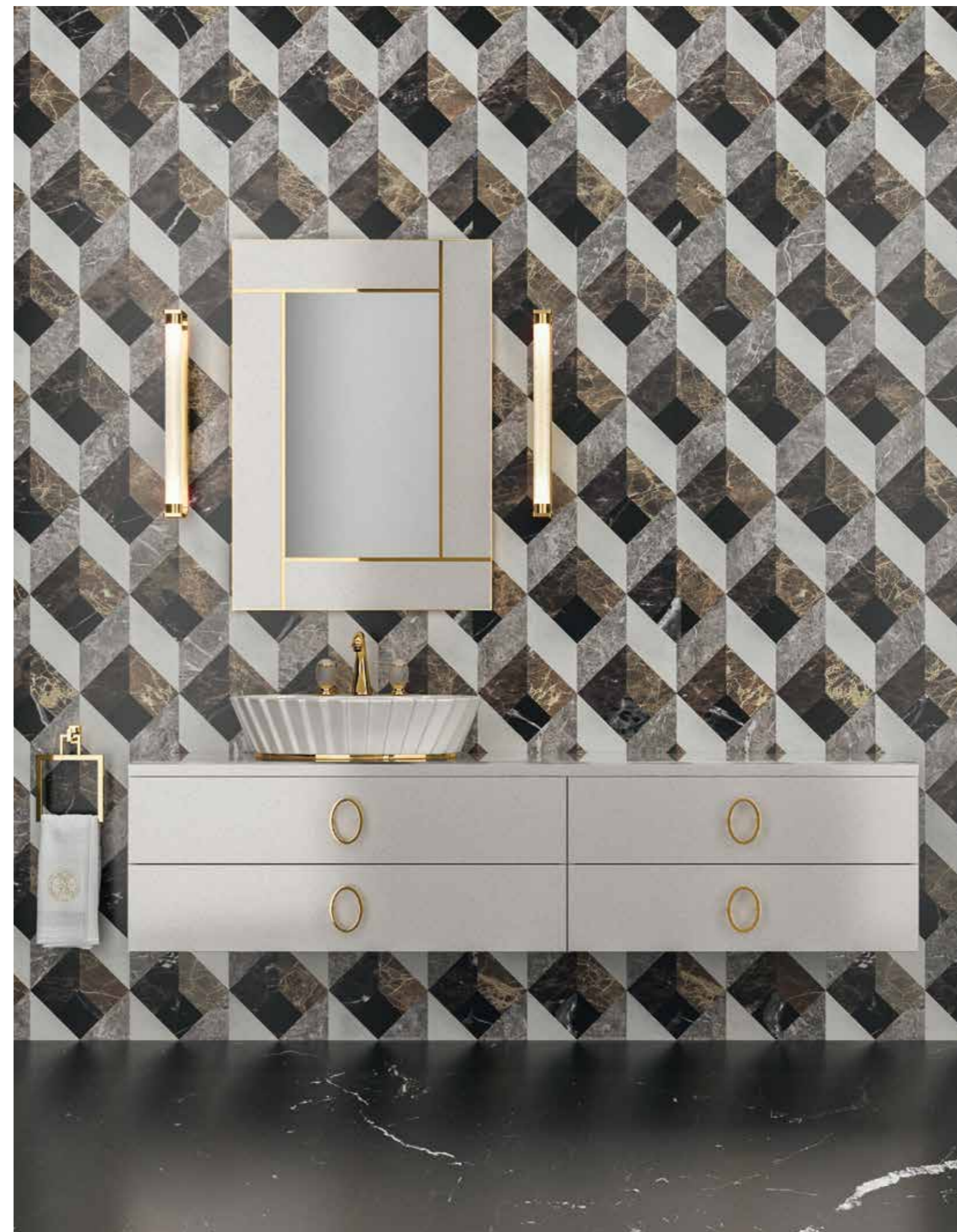



# Technical Drawing

## PLISSÉ PL1

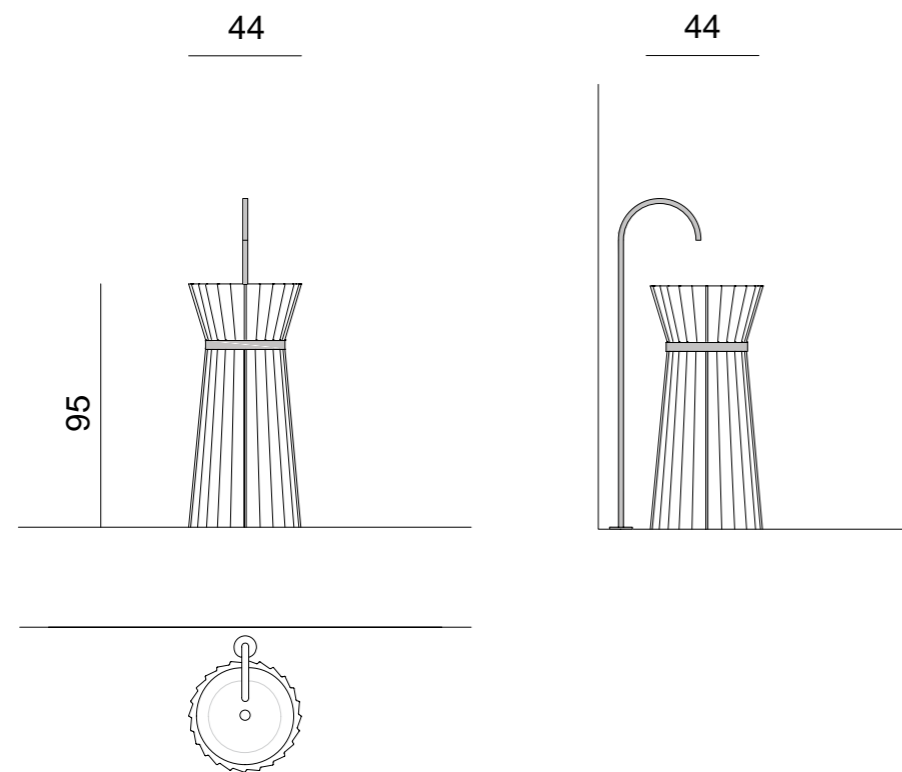

## DAPHNE D33

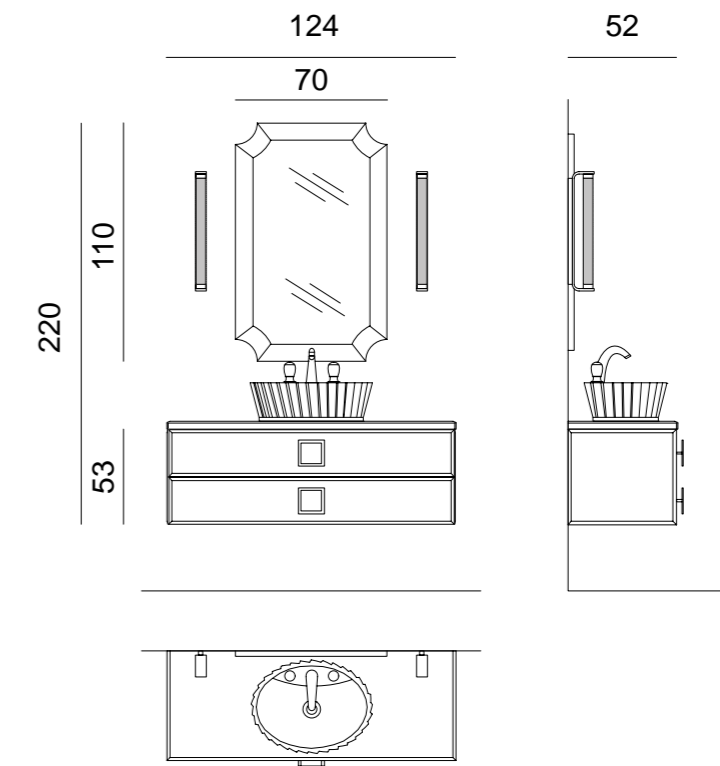

## DAPHNE D30

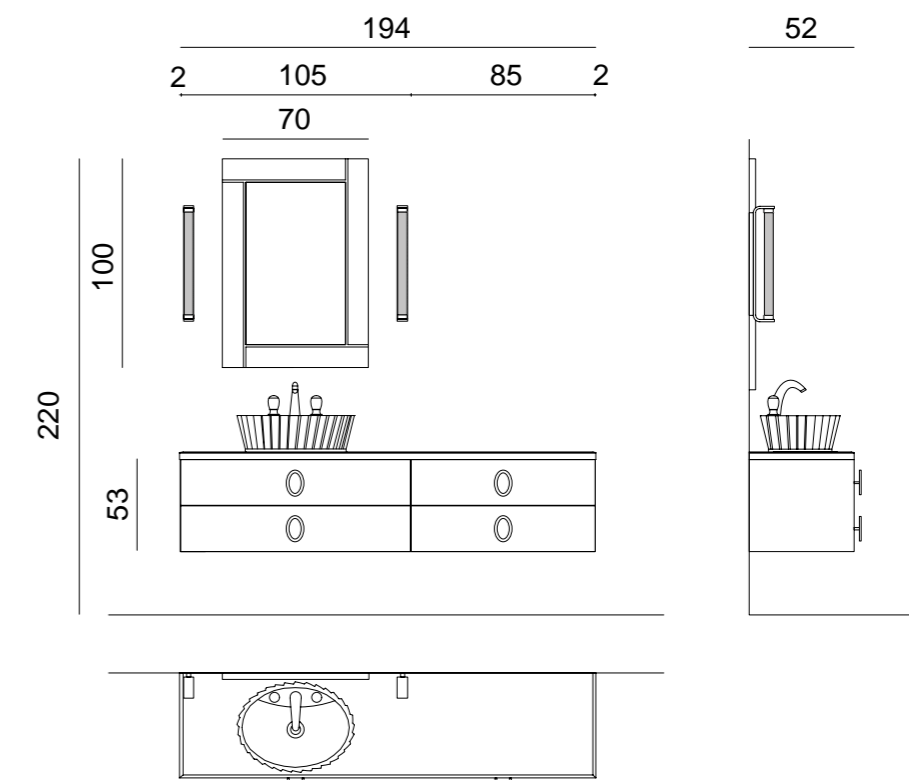



MADE IN ITALY

100% designed and made in Italy.

All Oasis products are protected by registered trademarks.

Oasis reserves the right to make all necessary modifications (in matters of colour, size and technical details) to its products in order to enhance their use and esthetic value.

Furthermore, it may suspend their production at any moment without notice. Such instances may not be subject to any claim on the part of the client.

Oasisgroup declines all responsibility for any possible uncertainties arising from misprints in this catalogue.

Edi.22 - Rev.00



Oasis Srl - Via Favola,19 - 33070 Polcenigo - Pordenone, Italy - T +39 0434 654752 - F +39 0434 654850  
info@oasisgroup.it - www.oasisgroup.it



[www.oasisgroup.it](http://www.oasisgroup.it)